

### Instructions:

1. Turn off power.
2. Remove hopper(s), auger(s) and lid(s) from unit.
3. From front of the dispenser, insert pick tool (Fig. 1 & 2) **into** auger shaft seal (A) (**NOT** between the seal and shaft) and pull forward rotating around auger shaft until removed and discard.

**Extreme care should be taken not to damage or scratch the ceramic portion of the auger shaft.**

4. Repeat for auger shaft bushing (B) and discard.

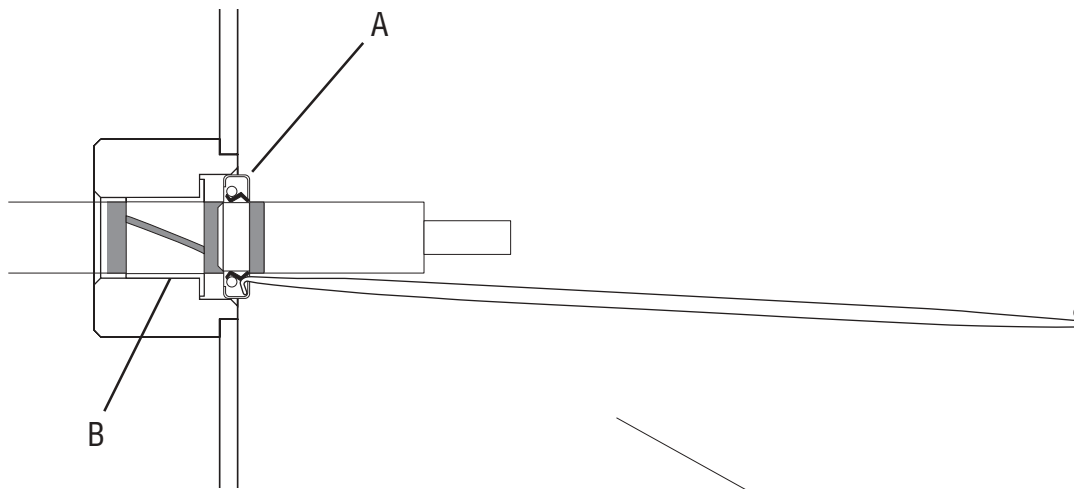

Fig. 1

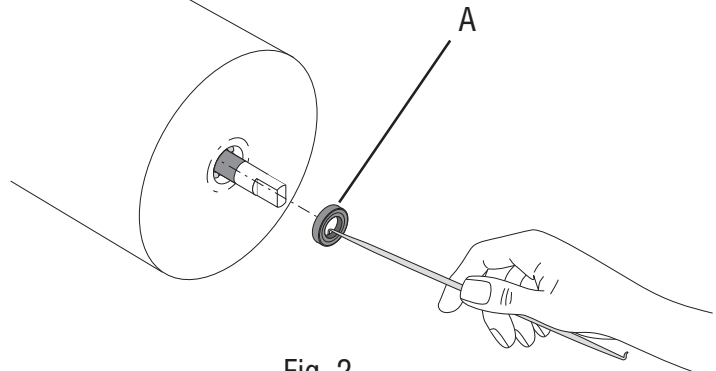

Fig. 2

(Continued)

**BUNN-O-MATIC CORPORATION**

POST OFFICE BOX 3227

SPRINGFIELD, ILLINOIS 62708-3227

PHONE: (217) 529-6601 FAX: (217) 529-6644

## Instructions for Removal & Replacement of Cooling Drum Seal & Bushing for ULTRA (cont.)

5. Clean seal and bushing surfaces of the cooling drum very thoroughly. Slide bushing (B) onto auger shaft and insert into bore of cooling drum until it is firmly seated using insertion tool (C).
6. If needed, lightly lube I.D. of cooling drum seal with #M2550.0000 "Lubri-film" to prevent seal roll. Make sure open face of seal is toward cooling drum and slide seal (A) onto auger shaft and insert into bore of cooling drum until properly seated against bushing (B) using insertion tool (Fig. 3).

**Note:** Properly installed cooling drum seal will be recessed in bore of cooling drum (Fig. 4).

7. Reinstall auger(s), hopper(s) and lid(s).

**Seal Insert Tool** – A hollow pipe with .75 in. O.D. (no larger) and .50 in. I.D. (no smaller) can be used as a seal insert tool.

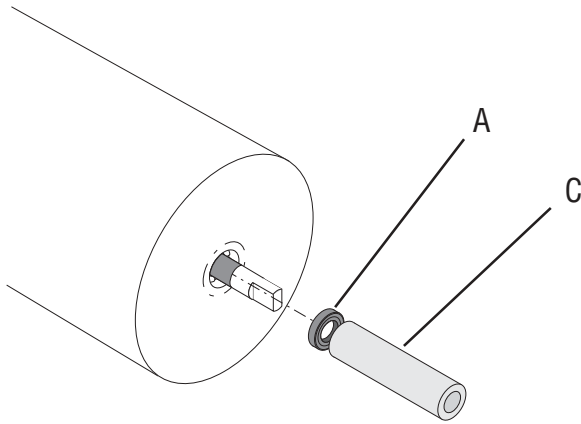

Fig. 3

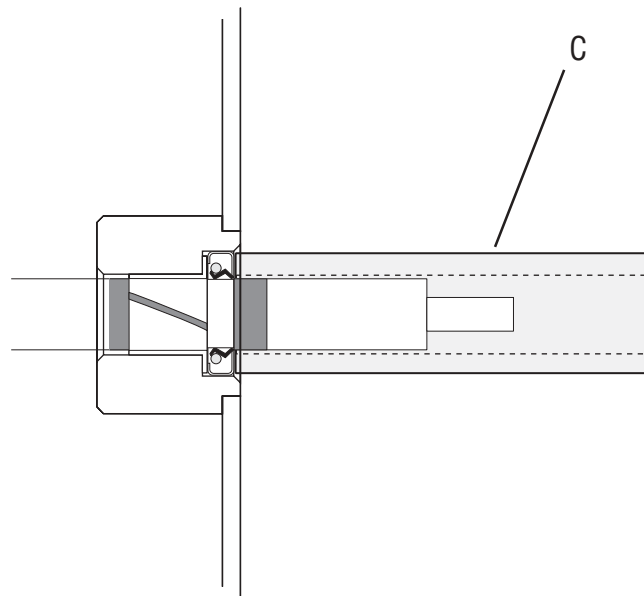

Fig. 4